



COMPACT M04

60W RMS, 4", 1.0" (1" v.c), 2 ウェイパッシブスピーカー

COMPACT M04 はさまざまな用途に使用できるコアキシャルタイプのコンパクトなパッシブスピーカーです。バランスの良いサウンドを高い明瞭度で再生でき、スムーズで幅広い周波数レスポンスを実現します。

●仕様

周波数特性 (-10 dB)	90 Hz – 20000 Hz
最大出力音圧 @ 1m	113 dB
水平指向角	120°
垂直指向角	120°
指向性係数 Q	6
システム感度	89 dB
公称インピーダンス	16 Ω
許容入力	240W Peak, 60W RMS
推奨パワーアンプ出力	120W
クロスオーバー周波数	1800 Hz
LF	4.0", 1.0" v.c
HF	1.0" neo, 1.0" v.c
入力端子	ユーロブロック
出力端子	ユーロブロック
キャビネット材質	合板
ハードウェア	M6 × 2, M8 × 2
グリル	スチール
色	黒 - RAL9005, 白 - RAL9003
寸法 (H × W × D)	148 × 132 × 145 mm
質量	2.3 kg
梱包時寸法 (H × W × D)	168 × 233 × 150 mm
梱包時質量	2.9 kg

●寸法図

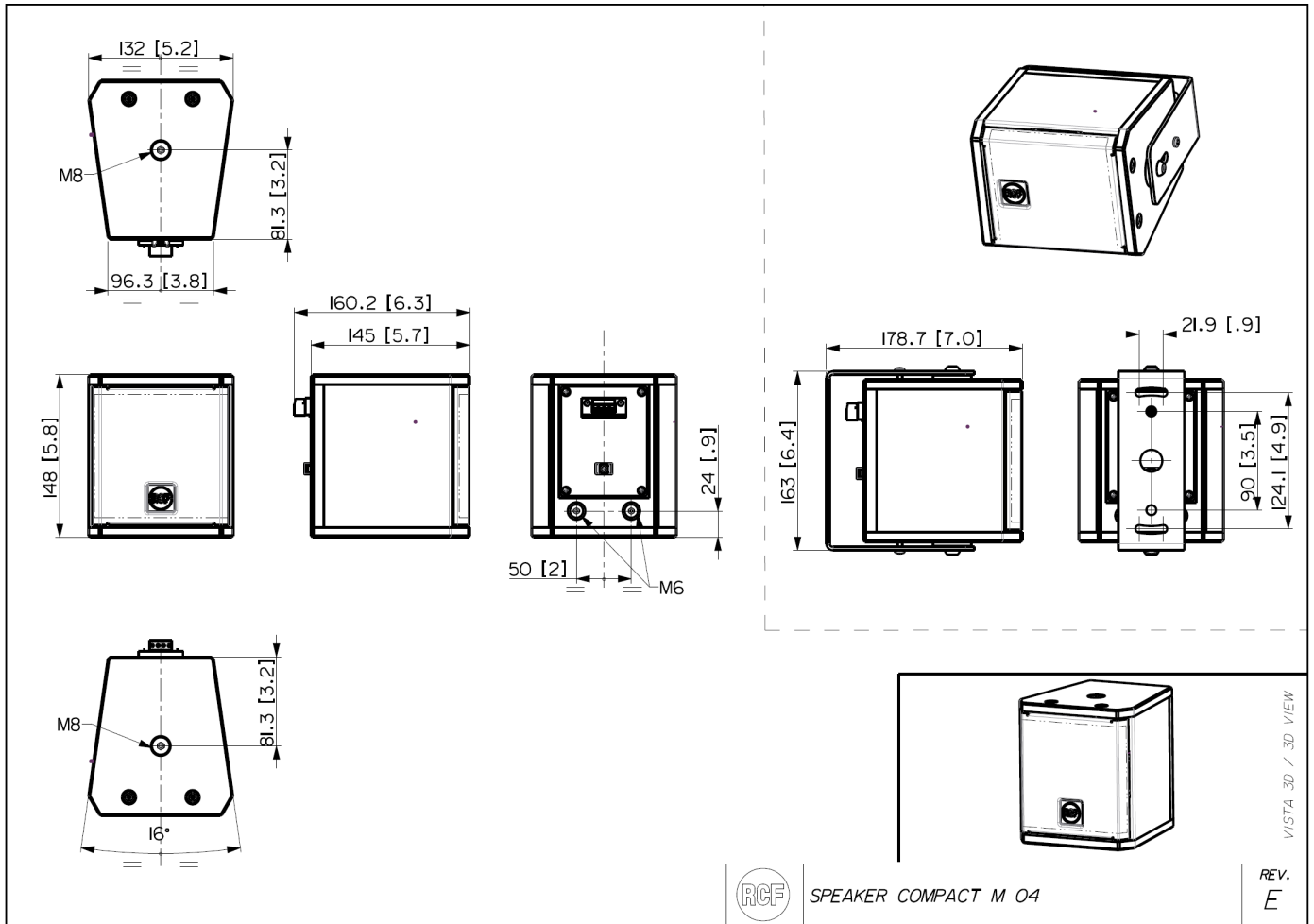

SPEAKER COMPACT M 04

REV.
E

VISTA 3D / 3D VIEW

●特性

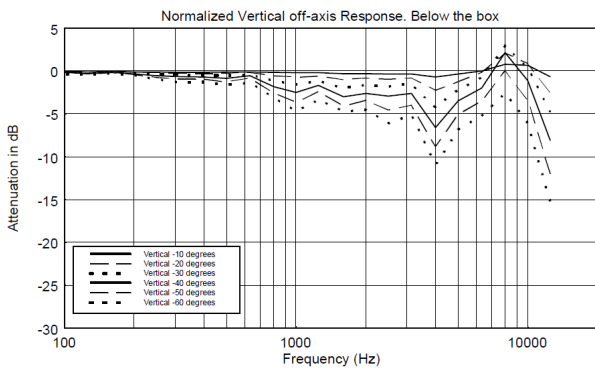
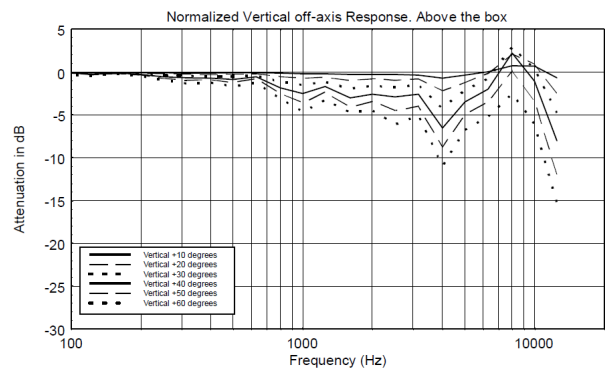
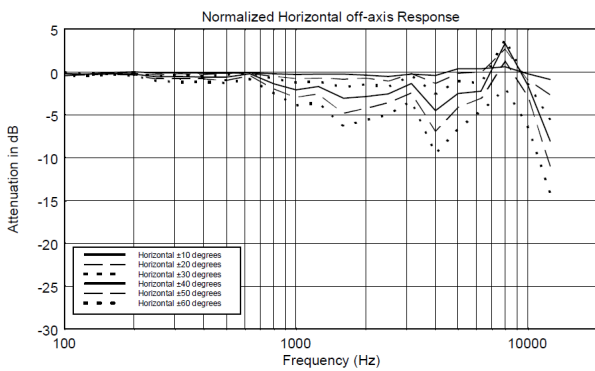
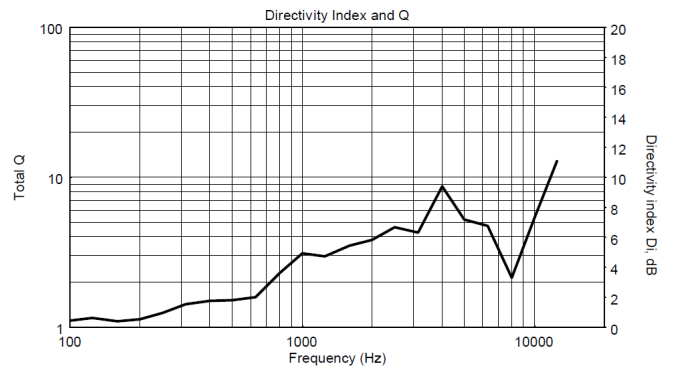
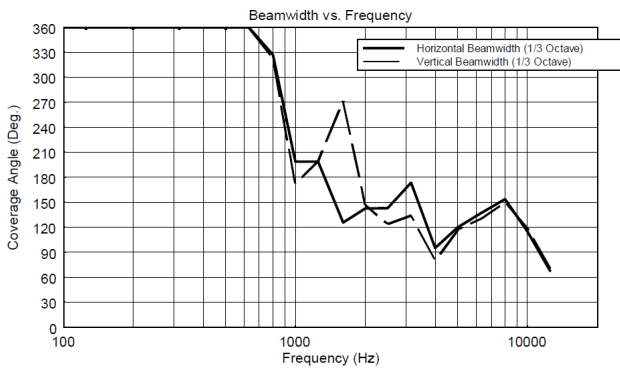
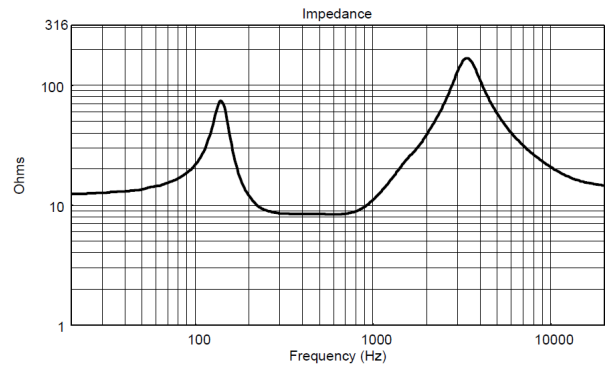
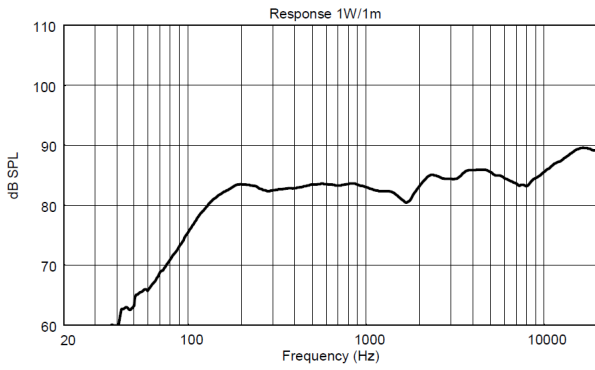

●水平ポラーパターン

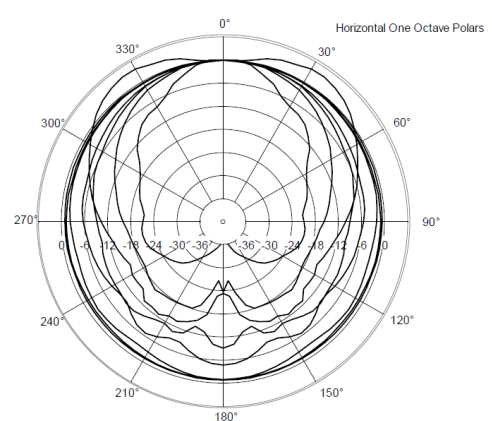
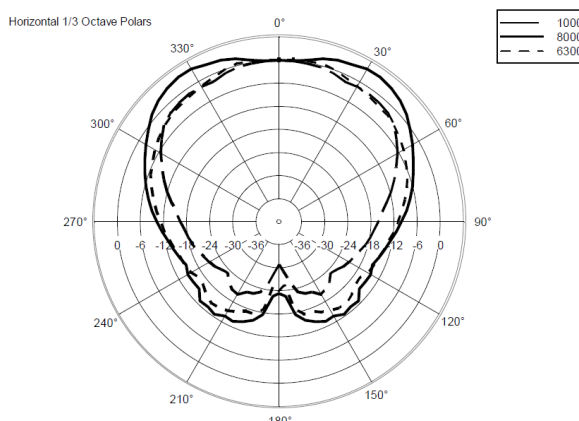
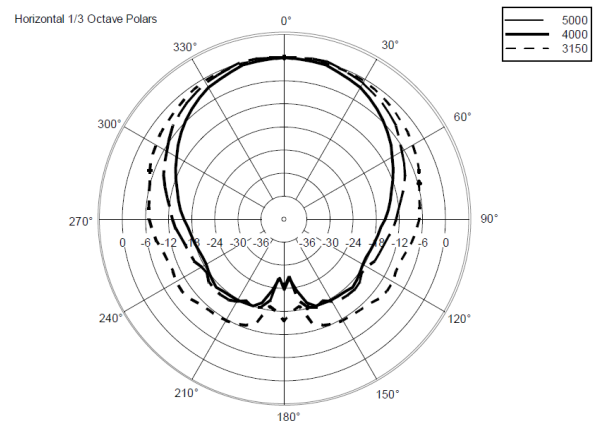
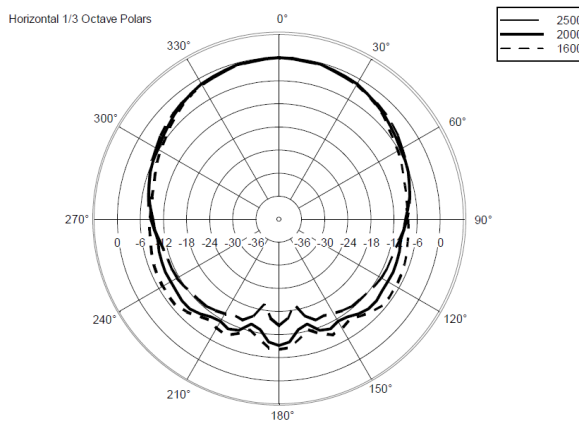
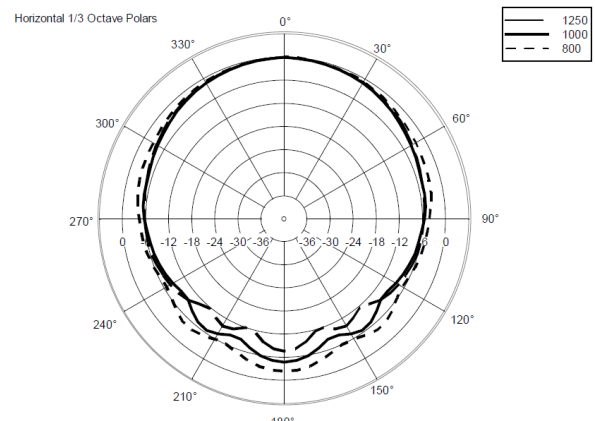
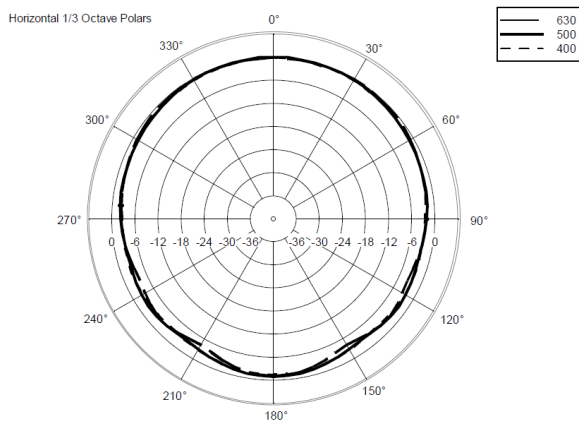
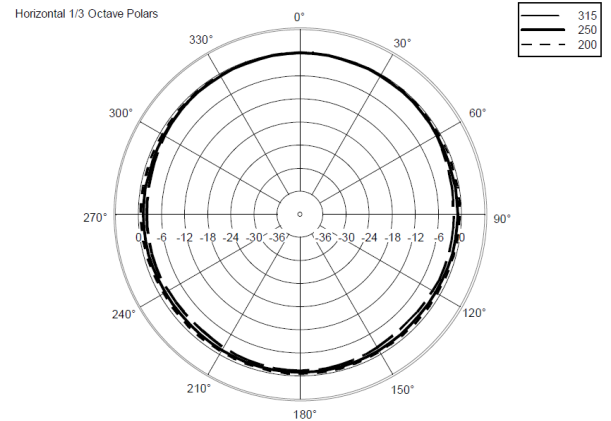
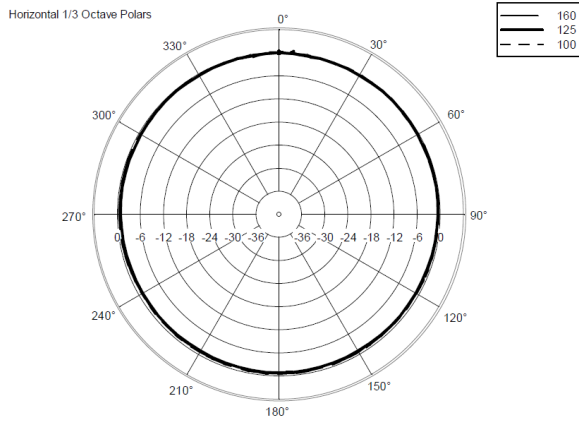

●垂直ポラーパターン

